

Data Display or Monitor Tube

CV6198

Maintenance Type

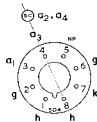
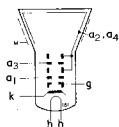

Base B8H, Cap CTS

GENERAL

Rectangular Face	—8½ in. Diagonal	Deflection Angle	—90° Diagonal
Electrostatic Focus	—Magnetic Deflection	Aluminised Screen	—Orange Trace
LG Phosphor	—Very Long Persistence	External Conductive Coating	
	Heater Voltage	V_h	11.5 V
	Heater Current	I_h	0.15 A

RATINGS

Maximum Second and Fourth Anode Voltage	$V_{a2,a4(max)}$	16 [*] kV
Minimum Second and Fourth Anode Voltage	$V_{a2,a4(min)}$	8.0 kV
Maximum Third Anode Voltage	$V_{a3(max)}$	700 V
Maximum First Anode Voltage	$V_{a1(max)}$	500 V
Maximum Heater to Cathode Voltage, Heater Negative (d.c.)	$V_{h-k(max)}$	200 V

*16 kV is a design centre rating, the absolute rating of 18 kV must not be exceeded. All voltages referred to cathode.

INTER-ELECTRODE CAPACITANCES

Grid to all	C_{g-all}	7.0	8.5	PF
Cathode to all	C_{c-all}	3.0	3.5	PF
Anode 2 and Anode 4 to External Conductive Coating (approx)	$C_{a2,a4-M}$	400		PF

* Inter-electrode capacitance with holder balanced out.
 † Inter-electrode capacitance including a typical B8H holder.

TYPICAL OPERATION—Grid Modulation (all voltages referred to cathode)

Second and Fourth Anode Voltage	$V_{a2,a4}$	14	kV
First Anode Voltage	V_{a1}	400	V
Third Anode Voltage for Focus (Range)	V_{a3}	0 to 400	V
Grid to Cathode Voltage for cut-off of Raster	V_g	-30 to -72	V
Average Peak to Peak Modulating Voltage for Modulation up to 150µA		24	V
LG Screen Persistence to 10% (approximate)		4.0	s

The LG screen is liable to burn even at low values of beam current if operated with a stationary or slow-moving spot.

Note

This tube can be supplied with a number of different phosphors as requested. This tube is fitted with a B8H Sparkguard S base, details of which are given on a separate sheet.

Net Tube Weight (approx)—1.36 kg (3 lb).

DATA DISPLAY & MONITOR TUBES

C.469

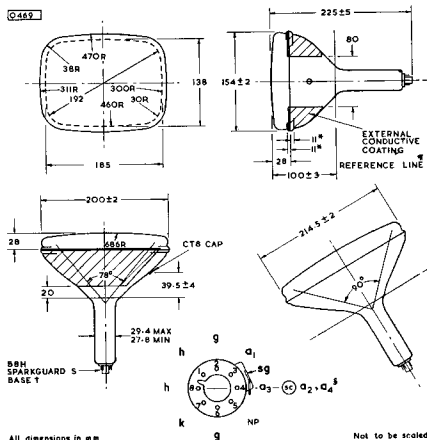

All dimensions in mm

Not to be scaled

There is an annular region of anti-corona coating with an external diameter of 60 mm surrounding the CT8 cap, the tube should not be handled in this region.

* During the face sealing operation the glass in this area (total 22 mm) may be disturbed. As the shape of the contour within this area may be either convex or concave the bulb should not be gripped within this region unless special precautions are taken (such as the use of resilient packing material).

† The socket for the B8H button base should not be rigidly mounted, it should have flexible leads and be allowed to move freely. The design of the socket should be such that the wiring cannot impress lateral strains through the socket contacts on the base.

‡ Anode cap in line with pin 4 ± 30°.

§ Determined by Reference Gauge No. 15.

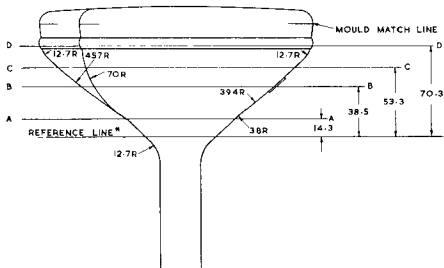

Ø47.0



MOULD MATCH DETAIL

MAXIMUM CONE SIZES AT POINTS A-A, B-B, C-C, D-D			
SEC'N	MAJOR AXIS	MINOR AXIS	DIAG'L
A-A	82.4	82.4	82.4
B-B	146	134	153
C-C	180	149	193
D-D	201	155	216

All dimensions in mm

Not to be scoled

* Determined by Reference Line Gauge No. 15.

DATA DISPLAY
& MONITOR
TUBES